

power**MILL**

GÜHRING

ÜNİVERSAL FREZE PROGRAMI

FİYAT VE VERİMLİLİK

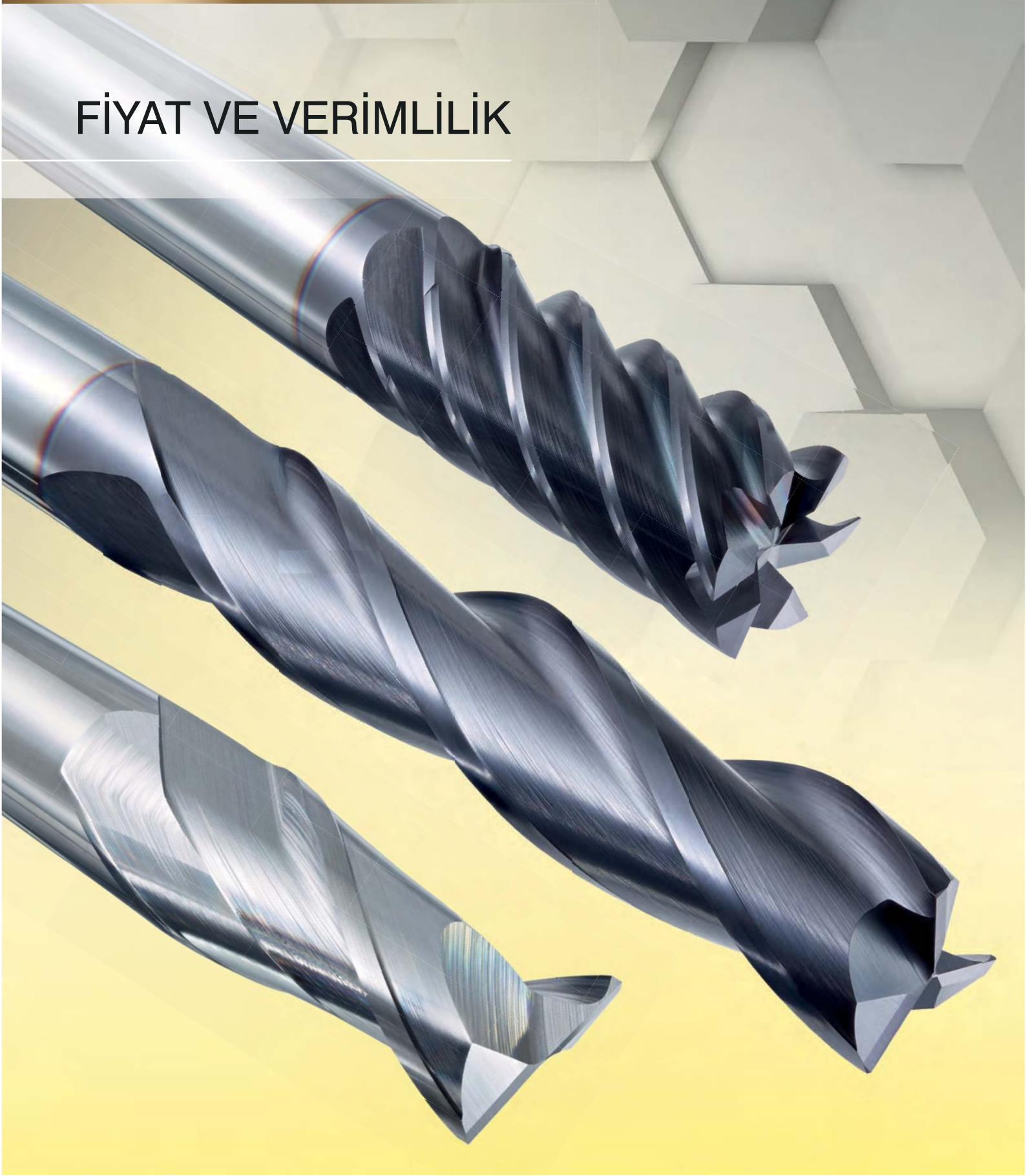

powerMILL

GUHRING POWERMILL PROGRAMI birinci sınıf fiyatlarda ve her yerde optimum performans veren frezeleri ile takım pazarına üniversal freze ürün yelpazesi sunuyor



FİYAT VE VERİMLİLİK

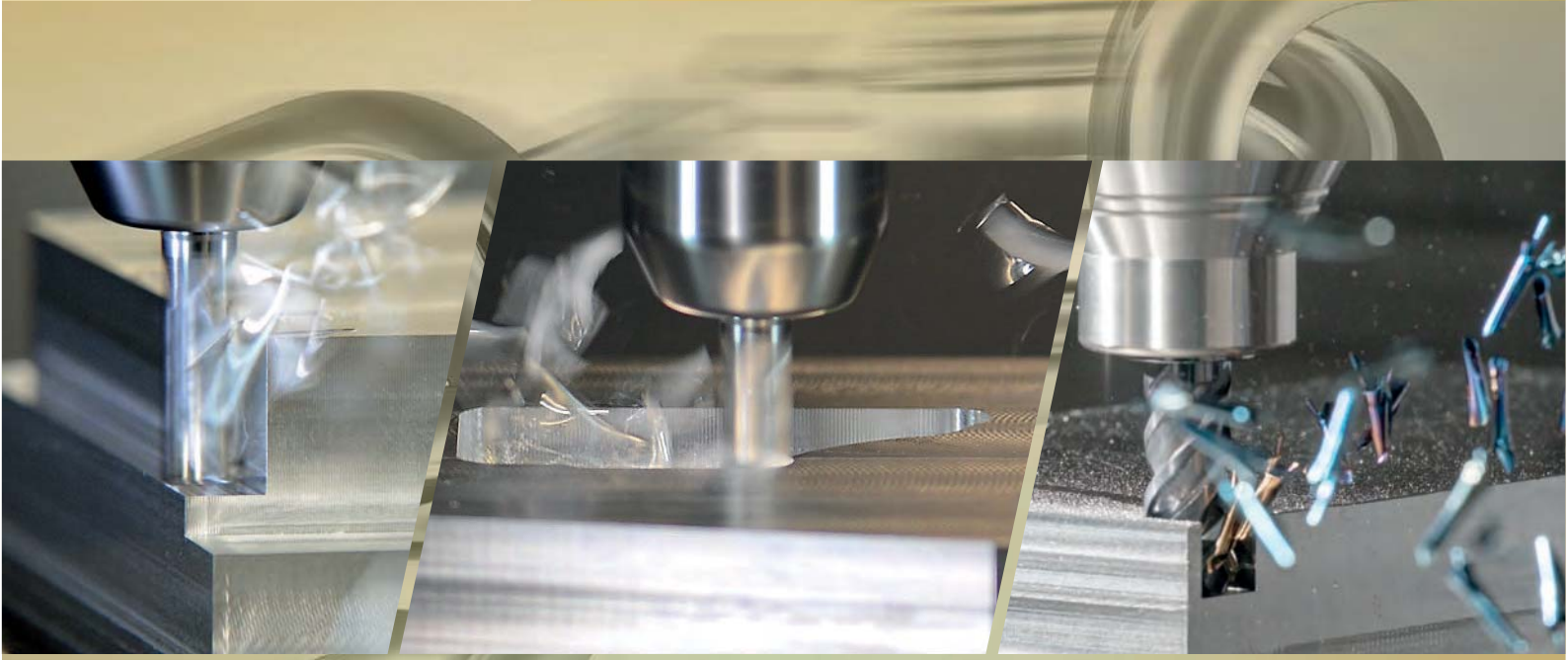

FİYAT VE VERİMLİLİK

GUHRING kesme ağız geometrileri, üniversal frezeleme işlemlerinde yüksek talaş kaldırma oranları ve daha uzun takım ömrü elde etmek için optimize edilmiştir. Yanı sıra POWERMILL Programına, frezeleme işlemine olan etkisi kanıtlanmış FIRE kaplamasınıda eklemiştir.

Maksimum performans için geliştirilen geometriler!

Özel olarak tasarlanmış tezgahlarda yüksek hassaslıkta taşlanır!

En yüksek oranda karbür kullanılan takımlar!

Heryerde kullanılabilen frezeleri ile tüm malzemelere uygun!









powerMILL

by **GUHRING**

















P	M	K	N	S	H	Takım Görüntüsü	Z	ilerleme	Saft Formu	Uzunluk	Malzeme	Yüzey	d1/mm	Artikel no	Kesme Bilgi Sayfa	Sayfa
Al slot markap frezeler (2-kesme ağızlı)																
							2		HA		VHM	○	2.000 - 20.000	19994	24	6
							2		HB		VHM	○	2.000 - 20.000	19995	24	6
							2		HA		VHM	○	2.000 - 20.000	19996	24	7
							2		HB		VHM	○	2.000 - 20.000	19997	24	7
Slot markap frezeler (3-kesme ağızlı)																
							3		HA		VHM	○	2.000 - 20.000	19992	24	8
							3		HB		VHM	○	2.000 - 20.000	19993	24	8
Slot markap frezeler (2-kesme ağızlı)																
							2		HA		VHM	⊗	2.000 - 20.000	19988	24	9
							2		HB		VHM	⊗	2.000 - 20.000	19989	24	9
							2		HA		VHM	⊗	3.000 - 20.000	19990	24	10
							2		HB		VHM	⊗	3.000 - 20.000	19991	24	10
Slot markap frezeler (3-kesme ağızlı)																
							3		HA		VHM	⊗	2.000 - 20.000	19986	24	11
							3		HB		VHM	⊗	2.000 - 20.000	19987	24	11
							3		HA		VHM	⊗	2.000 - 20.000	19982	24	12
							3		HB		VHM	⊗	2.000 - 20.000	19983	24	12
							3		HA		VHM	⊗	3.000 - 20.000	19984	24	13
							3		HB		VHM	⊗	3.000 - 20.000	19985	24	13
HPC finiş frezeler (4-kesme ağızlı)																
							4		HA		VHM	⊗	3.000 - 20.000	19980	24	14
							4		HB		VHM	⊗	3.000 - 20.000	19981	24	14
Finiş frezeler (4-kesme ağızlı)																
							4		HA		VHM	⊗	2.000 - 20.000	19978	26	15
							4		HB		VHM	⊗	2.000 - 20.000	19979	26	15

P	M	K	N	S	H	Takım Görüntüsü	Z	ilerleme	Soft Formu	Uzunluk	Malzeme	Yüzey	d1/mm	Artikel no	Kesme Bilgi Sayfa	Sayfa
---	---	---	---	---	---	-----------------	---	----------	------------	---------	---------	-------	-------	------------	-------------------	-------

















Finiş Frezeler (4-kesme ağızlı)

•	•	•	•	•	•				HA		VHM	F	3.000 - 20.000	19976	26	16
•	•	•	•	•	•				HB		VHM	F	3.000 - 20.000	19977	26	16

















Çok ağızlı finiş frezeler (6-Kesme ağızlı)

•	•	•	•	•	•				HA		VHM	F	3.000 - 20.000	19972	26	17
•	•	•	•	•	•				HB		VHM	F	3.000 - 20.000	19973	26	17
•	•	•	•	•	•				HA		VHM	F	4.000 - 20.000	19974	26	18
•	•	•	•	•	•				HB		VHM	F	4.000 - 20.000	19975	26	18

Küresel Slot Matkap Frezeleri (2-kesme ağızlı)

•	•	•	•	•	•				HA		VHM	F	2.000 - 20.000	19968	26	19
•	•	•	•	•	•				HB		VHM	F	2.000 - 20.000	19969	26	19
•	•	•	•	•	•				HA		VHM	F	3.000 - 12.000	19970	26	20
•	•	•	•	•	•				HB		VHM	F	3.000 - 12.000	19971	26	20

Kaba ve Finiş Frezeler

•	•	•	•	•	•				HA		VHM	F	4.000 - 20.000	19964	24	21
•	•	•	•	•	•				HB		VHM	F	4.000 - 20.000	19965	24	21
•	•	•	•	•	•				HA		VHM	F	5.000 - 25.000	19966	24	22
•	•	•	•	•	•				HB		VHM	F	5.000 - 25.000	19967	24	22

Al slot makrap freze (2-kesme ağızlı)

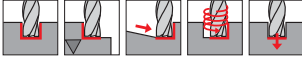
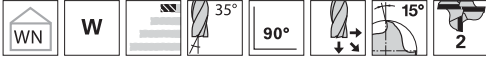

P	
M	
K	
N	•
S	
H	

GUHRING NAVIGATOR
Kesme Şartları Sayfa 24

Merkez kesmeli

Malzeme	Karbür	
Kaplama Tipi	○	○
Tip	W	W
Şaft Formu	HA	HB

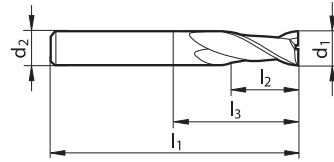

							Artikel no	19994	19995
							İndirim grubu	206	206
d1 e8	d2 h6	l1	l2	l3	Z	Kod no	EUR/parça		
mm	mm	mm	mm	mm					
2.000	4.000	40.000	3.000	6.400	2	2.000	8.30		
3.000	4.000	40.000	4.000	8.900	2	3.000	8.30		
4.000	6.000	50.000	5.000	10.400	2	4.000	8.30	9.10	
5.000	6.000	50.000	6.000	12.900	2	5.000	8.30	9.10	
6.000	6.000	50.000	7.000	14.000	2	6.000	8.30	9.10	
8.000	8.000	58.000	9.000	22.000	2	8.000	10.00	10.80	
10.000	10.000	66.000	11.000	26.000	2	10.000	13.40	14.60	
12.000	12.000	73.000	12.000	28.000	2	12.000	21.50	22.70	
14.000	14.000	75.000	14.000	30.000	2	14.000	29.50	30.70	
16.000	16.000	82.000	16.000	34.000	2	16.000	32.00	34.00	
18.000	18.000	84.000	18.000	36.000	2	18.000	43.50	45.50	
20.000	20.000	92.000	20.000	42.000	2	20.000	58.00	60.00	

Al slot mükâp frezeler (3-kesme ağızlı)

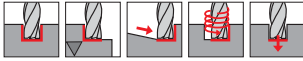
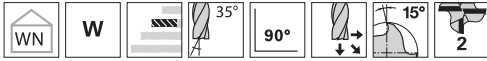

P	
M	
K	
N	•
S	
H	

GUHRING NAVIGATOR
Kesme Şartları Sayfa 24

Merkez kesmeli

Malzeme	Karbür	
Kaplama Tipi	○	○
Tip	W	W
Şaft Formu	HA	HB

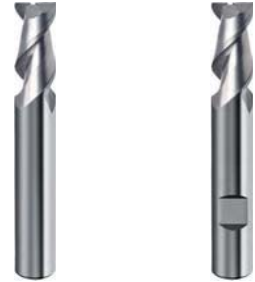
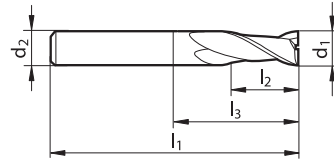

							Artikel no	19996	19997
							İndirim grubu	206	206
d1 e8	d2 h6	l1	l2	l3	Z	Kod no	EUR/parça		
mm	mm	mm	mm	mm					
2.000	4.000	40.000	7.000	10.400	2	2.000	10.80		
3.000	4.000	50.000	9.000	13.900	2	3.000	10.80		
4.000	6.000	57.000	11.000	16.400	2	4.000	10.80	11.60	
5.000	6.000	57.000	13.000	19.900	2	5.000	10.80	11.60	
6.000	6.000	57.000	13.000	21.000	2	6.000	10.80	11.60	
8.000	8.000	63.000	19.000	28.000	2	8.000	12.30	13.10	
10.000	10.000	72.000	22.000	33.000	2	10.000	21.50	22.70	
12.000	12.000	83.000	26.000	40.000	2	12.000	32.00	33.20	
14.000	14.000	83.000	26.000	41.000	2	14.000	39.00	40.20	
16.000	16.000	92.000	32.000	49.000	2	16.000	52.00	54.00	
18.000	18.000	92.000	32.000	50.000	2	18.000	62.00	64.00	
20.000	20.000	104.000	38.000	58.000	2	20.000	82.00	84.00	

Slot makap frezeler (3-kesme ağızlı)

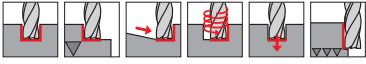

P	
M	○
K	
N	●
S	○
H	

GUHRING NAVIGATOR

Kesme Şartları Sayfa 24

Pürüzsüz kesme işlemi için yüksek helis açısına sahip yüksek performanslı slot makap • Merkez Kesme • Delme Kesici Ağız geometri

SLOT FREZE

Malzeme	Karbür	
Kaplama Tipi	○	○
Tip	W	W
Şaft Formu	HA	HB

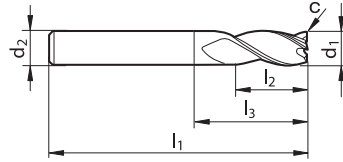

								Artikel no	19992	19993
								İndirim grubu	206	206
d1 e8	d2 h6	l1	l2	l3	c	Z	Kod no	EUR/parça		
mm	mm	mm	mm	mm	mm x 45°					
2.000	4.000	50.000	6.000	8.900	0.030	3	2.000	11.40		
3.000	6.000	57.000	8.000	11.900	0.050	3	3.000	10.40	11.20	
4.000	6.000	57.000	11.000	14.900	0.060	3	4.000	9.80	10.60	
5.000	6.000	57.000	13.000	18.400	0.080	3	5.000	9.80	10.60	
6.000	6.000	57.000	13.000	21.000	0.090	3	6.000	10.40	11.20	
8.000	8.000	63.000	19.000	27.000	0.120	3	8.000	11.80	12.60	
10.000	10.000	72.000	22.000	32.000	0.150	3	10.000	20.00	21.20	
12.000	12.000	83.000	26.000	38.000	0.180	3	12.000	29.00	30.20	
14.000	14.000	83.000	26.000	38.000	0.210	3	14.000	36.00	37.20	
16.000	16.000	92.000	32.000	44.000	0.190	3	16.000	52.00	54.00	
20.000	20.000	104.000	38.000	54.000	0.240	3	20.000	84.00	86.00	

Slot maklap frezeler (2-kesme ağızlı)

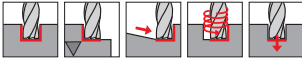
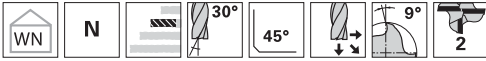

P	•
M	•
K	•
N	○
S	•
H	

GÜHRING NAVIGATOR
Kesme Şartları Sayfa 24

Merkez kesme • Delme Kesici Ağız geometri

Malzeme	Karbür	
Kaplama Tipi	F	F
Tip	N	N
Şaft Formu	HA	HB

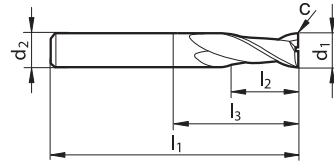

Artikel no 19988 19989

İndirim grubu 206 206

d1 e8	d2 h6	l1	l2	l3	c	Z	Kod no	EUR/parça	
mm	mm	mm	mm	mm	mm x 45°				
2.000	4.000	40.000	6.000	9.400	0.020	2	2.000	12.80	
3.000	4.000	50.000	8.000	12.900	0.030	2	3.000	12.50	
4.000	6.000	50.000	11.000	16.400	0.040	2	4.000	12.30	13.10
5.000	6.000	50.000	13.000	19.900	0.050	2	5.000	12.30	13.10
6.000	6.000	50.000	13.000	20.000	0.060	2	6.000	12.00	12.80
7.000	8.000	60.000	16.000	23.100	0.070	2	7.000	20.00	20.80
8.000	8.000	60.000	19.000	27.000	0.080	2	8.000	16.00	16.80
9.000	10.000	70.000	19.000	29.100	0.090	2	9.000	28.00	29.20
10.000	10.000	70.000	22.000	30.000	0.100	2	10.000	23.50	24.70
11.000	12.000	75.000	22.000	29.100	0.110	2	11.000	31.00	32.20
12.000	12.000	75.000	26.000	39.000	0.120	2	12.000	33.50	34.70
14.000	14.000	75.000	26.000	40.000	0.140	2	14.000	45.50	46.70
16.000	16.000	75.000	26.000	43.000	0.160	2	16.000	67.00	69.00
18.000	18.000	100.000	32.000	52.000	0.180	2	18.000	84.00	86.00
20.000	20.000	100.000	32.000	50.000	0.200	2	20.000	88.00	90.00

XL slot malzeme frezeler (2-kesme ağızlı)

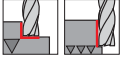
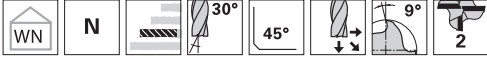

P	•
M	•
K	•
N	○
S	•
H	

GÜHRING NAVIGATOR

Kesme Şartları Sayfa 24

Merkez kesme • Delme Kesici Ağız geometri

Malzeme	Karbür	
Kaplama Tipi	F	F
Tip	N	N
Şaft Formu	HA	HB

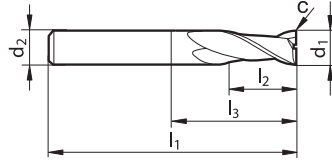

								Artikel no	19990	19991
								İndirim grubu	206	206
d1 e8	d2 h6	l1	l2	l3	c	Z	Kod no	EUR/parça		
mm	mm	mm	mm	mm	mm x 45°					
3.000	3.000	60.000	20.000	32.000	0.030	2	3.000	15.10		
4.000	4.000	60.000	20.000	32.000	0.040	2	4.000	16.80		
5.000	5.000	75.000	25.000	47.000	0.050	2	5.000	17.80		
6.000	6.000	75.000	30.000	39.000	0.060	2	6.000	17.80	18.60	
8.000	8.000	75.000	30.000	39.000	0.080	2	8.000	34.00	34.80	
10.000	10.000	100.000	40.000	60.000	0.100	2	10.000	41.50	42.70	
12.000	12.000	100.000	45.000	55.000	0.120	2	12.000	64.00	65.20	
14.000	14.000	100.000	45.000	55.000	0.140	2	14.000	83.00	84.20	
16.000	16.000	100.000	45.000	62.000	0.160	2	16.000	103.00	105.00	
18.000	18.000	100.000	45.000	63.000	0.180	2	18.000	120.00	122.00	
20.000	20.000	100.000	45.000	62.000	0.200	2	20.000	139.00	141.00	

Slot map frezeler (3-kesme azlı)

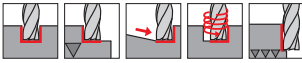
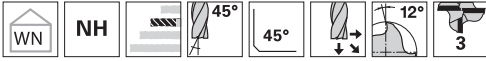

P	•
M	•
K	•
N	o
S	•
H	

GHRING NAVIGATOR

Kesme Őartları Sayfa 24

Przsz kesme iŐlemi iin yksek helis aısına sahip yksek performanslı slot map • Merkez Kesme • Delme Kesici Aız geometrili

Malzeme	Karbr	
Kaplama Tipi	F	F
Tip	NH	NH
Őaft Formu	HA	HB

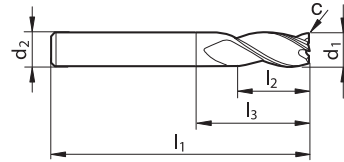

Artikel no 19986 19987

İndirim grubu 206 206

d1 e8	d2 h6	l1	l2	l3	c	Z	Kod no	EUR/para	
mm	mm	mm	mm	mm	mm x 45°				
2.000	4.000	50.000	6.000	8.900	0.030	3	2.000	13.60	
3.000	6.000	57.000	8.000	11.900	0.050	3	3.000	12.40	13.20
4.000	6.000	57.000	11.000	14.900	0.060	3	4.000	12.20	13.00
5.000	6.000	57.000	13.000	18.400	0.080	3	5.000	12.20	13.00
6.000	6.000	57.000	13.000	21.000	0.090	3	6.000	12.60	13.40
8.000	8.000	63.000	19.000	27.000	0.120	3	8.000	16.20	17.00
10.000	10.000	72.000	22.000	32.000	0.150	3	10.000	23.00	24.20
12.000	12.000	83.000	26.000	38.000	0.180	3	12.000	36.00	37.20
14.000	14.000	83.000	26.000	38.000	0.210	3	14.000	44.00	45.20
16.000	16.000	92.000	32.000	44.000	0.190	3	16.000	59.00	61.00
20.000	20.000	104.000	38.000	54.000	0.240	3	20.000	95.00	97.00

Slot makap frezeler (3-kesme ağızlı)

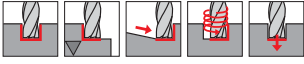
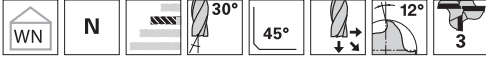

- P •
- M •
- K •
- N ○
- S •
- H

GÜHRING NAVIGATOR

Kesme Şartları Sayfa 24

Merkez kesme • Delme Kesici Ağız geometri

Malzeme	Karbür	
Kaplama Tipi	F	F
Tip	N	N
Şaft Formu	HA	HB

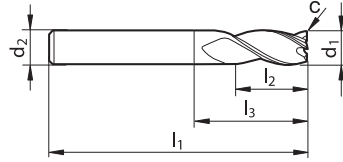

								Artikel no	19982	19983
								İndirim grubu	206	206
d1 e8	d2 h6	l1	l2	l3	c	Z	Kod no	EUR/parça		
mm	mm	mm	mm	mm	mm x 45°					
2.000	4.000	50.000	6.000	9.400	0.030	3	2.000	12.50		
3.000	6.000	57.000	8.000	12.900	0.050	3	3.000	12.50	13.30	
4.000	6.000	57.000	11.000	16.400	0.060	3	4.000	12.30	13.10	
5.000	6.000	57.000	13.000	19.900	0.080	3	5.000	12.00	12.80	
6.000	6.000	57.000	13.000	21.000	0.090	3	6.000	12.00	12.80	
8.000	8.000	63.000	19.000	27.000	0.120	3	8.000	16.00	16.80	
10.000	10.000	72.000	22.000	32.000	0.150	3	10.000	23.50	24.70	
12.000	12.000	83.000	26.000	38.000	0.180	3	12.000	36.00	37.20	
14.000	14.000	83.000	26.000	38.000	0.210	3	14.000	45.00	46.20	
16.000	16.000	92.000	32.000	44.000	0.190	3	16.000	56.00	58.00	
20.000	20.000	104.000	38.000	54.000	0.240	3	20.000	88.00	90.00	

Slot matris frezeler XL (3-kesme ağızlı)

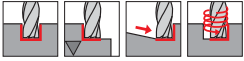
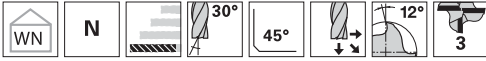

P	•
M	•
K	•
N	○
S	•
H	

GÜHRING NAVIGATOR

Kesme Şartları Sayfa 24

Merkez kesme • Delme Kesici Ağız geometri

Malzeme	Karbür	
Kaplama Tipi	F	F
Tip	N	N
Şaft Formu	HA	HB

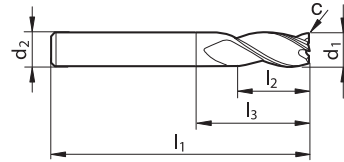

Artikel no 19984 19985

İndirim grubu 206 206

d1 e8	d2 h6	l1	l2	l3	c	Z	Kod no	EUR/parça	
mm	mm	mm	mm	mm	mm x 45°				
3.000	6.000	57.000	12.000	16.900	0.050	3	3.000	20.00	20.80
4.000	6.000	63.000	19.000	24.400	0.060	3	4.000	21.50	22.30
5.000	6.000	68.000	24.000	30.900	0.080	3	5.000	24.00	24.80
6.000	6.000	72.000	24.000	36.000	0.090	3	6.000	31.50	32.30
8.000	8.000	88.000	38.000	52.000	0.120	3	8.000	40.50	41.30
10.000	10.000	95.000	45.000	55.000	0.150	3	10.000	53.00	54.20
12.000	12.000	110.000	53.000	65.000	0.180	3	12.000	76.00	77.20
14.000	14.000	110.000	53.000	65.000	0.210	3	14.000	109.00	110.20
16.000	16.000	125.000	63.000	80.000	0.190	3	16.000	143.00	145.00
20.000	20.000	141.000	75.000	95.000	0.240	3	20.000	187.00	189.00

HPC Finiş Frezeler (4-kesme ağızlı)

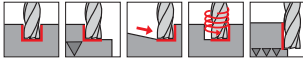

P	•
M	•
K	•
N	○
S	•
H	○

GUHRING NAVIGATOR
Kesme Şartları Sayfa 24

Değişken helis açısına sahip yüksek performanslı freze • Merkez kesme

Malzeme	Karbür	
Kaplama Tipi	•	•
Tip	N	N
Şaft Formu	HA	HB

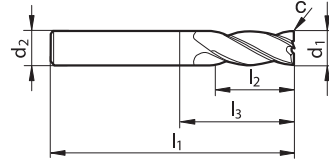

								Artikül no	19980	19981
								İndirim grubu	206	206
d1 e8	d2 h6	l1	l2	l3	c	Z	Kod no	EUR/parça		
mm	mm	mm	mm	mm	mm x 45°					
3.000	6.000	57.000	8.000	11.400	0.060	4	3.000	15.40	16.20	
4.000	6.000	57.000	11.000	14.900	0.080	4	4.000	15.40	16.20	
5.000	6.000	57.000	13.000	17.400	0.100	4	5.000	15.40	16.20	
6.000	6.000	57.000	13.000	21.000	0.120	4	6.000	18.80	19.60	
8.000	8.000	63.000	19.000	27.000	0.160	4	8.000	26.00	26.80	
10.000	10.000	72.000	22.000	32.000	0.200	4	10.000	39.50	40.70	
12.000	12.000	83.000	26.000	38.000	0.240	4	12.000	50.00	51.20	
14.000	14.000	83.000	26.000	38.000	0.280	4	14.000	68.00	69.20	
16.000	16.000	92.000	32.000	44.000	0.320	4	16.000	87.00	89.00	
20.000	20.000	104.000	38.000	54.000	0.400	4	20.000	135.00	137.00	

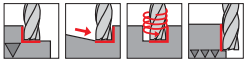
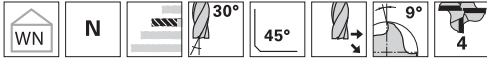

P	•
M	•
K	•
N	○
S	•
H	○

GÜHRING NAVIGATOR

Kesme Şartları Sayfa 26

Merkez kesmeli

Malzeme	Karbür	
Kaplama Tipi	●	●
Tip	N	N
Şaft Formu	HA	HB

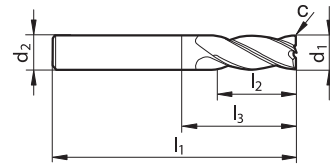

								Artikel no	19978	19979
								İndirim grubu	206	206
d1 e8	d2 h6	l1	l2	l3	c	Z	Kod no	EUR/parça		
mm	mm	mm	mm	mm	mm x 45°					
2.000	2.000	32.000	8.000	10.000	0.025	4	2.000	9.10		
3.000	3.000	38.000	12.000	15.000	0.050	4	3.000	9.10		
4.000	4.000	40.000	12.000	16.000	0.050	4	4.000	10.00		
5.000	5.000	50.000	15.000	20.000	0.050	4	5.000	10.00		
6.000	6.000	57.000	16.000	21.000	0.050	4	6.000	16.20	17.00	
7.000	8.000	60.000	16.000	23.900	0.100	4	7.000	13.10	13.90	
8.000	8.000	68.000	22.000	32.000	0.100	4	8.000	23.00	23.80	
9.000	10.000	72.000	22.000	28.400	0.100	4	9.000	21.50	22.70	
10.000	10.000	72.000	25.000	32.000	0.100	4	10.000	33.50	34.70	
11.000	12.000	83.000	26.000	27.600	0.100	4	11.000	48.00	49.20	
12.000	12.000	83.000	28.000	38.000	0.100	4	12.000	43.50	44.70	
14.000	14.000	83.000	28.000	38.000	0.150	4	14.000	58.00	59.20	
16.000	16.000	92.000	35.000	44.000	0.150	4	16.000	74.00	76.00	
18.000	18.000	92.000	35.000	44.000	0.150	4	18.000	98.00	100.00	
20.000	20.000	104.000	40.000	54.000	0.150	4	20.000	116.00	118.00	

XL finiş frezeler (4-kesme ağızlı)

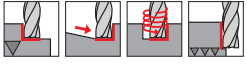
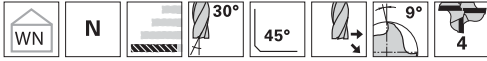

P	•
M	•
K	•
N	○
S	•
H	○

GÜHRING NAVIGATOR

Kesme Şartları Sayfa 26

Merkez kesmeli

Malzeme	Karbür	
Kaplama Tipi	F	F
Tip	N	N
Şaft Formu	HA	HB

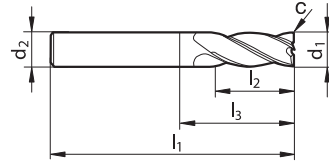

								Artikel no	19976	19977
								İndirim grubu	206	206
d1 e8	d2 h6	l1	l2	l3	c	Z	Kod no	EUR/parça		
mm	mm	mm	mm	mm	mm x 45°					
3.000	6.000	57.000	15.000	19.900	0.050	4	3.000	17.80	18.60	
4.000	6.000	63.000	19.000	25.400	0.050	4	4.000	20.00	20.80	
5.000	6.000	68.000	24.000	31.400	0.050	4	5.000	21.50	22.30	
6.000	6.000	68.000	24.000	32.000	0.050	4	6.000	27.00	27.80	
8.000	8.000	88.000	38.000	52.000	0.100	4	8.000	28.00	28.80	
10.000	10.000	95.000	45.000	55.000	0.100	4	10.000	40.00	41.20	
12.000	12.000	110.000	53.000	65.000	0.100	4	12.000	64.00	65.20	
14.000	14.000	110.000	53.000	65.000	0.150	4	14.000	76.00	77.20	
16.000	16.000	125.000	63.000	77.000	0.150	4	16.000	96.00	98.00	
18.000	18.000	125.000	63.000	77.000	0.150	4	18.000	118.00	120.00	
20.000	20.000	141.000	75.000	91.000	0.150	4	20.000	126.00	128.00	

Çok ağızlı finiş freze (6-kesme ağızlı)

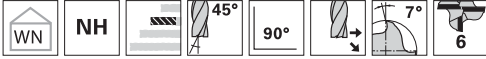

P	•
M	•
K	•
N	•
S	•
H	○

GUHRING NAVIGATOR
Kesme Şartları Sayfa 26

Merkez kesmesiz

Malzeme	Karbür	
Kaplama Tipi	•	•
Tip	NH	NH
Şaft Formu	HA	HB

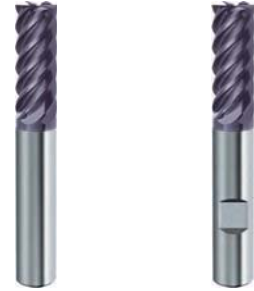
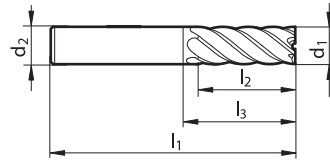

							Artikel no	19972	19973
							İndirim grubu	206	206
d1 e8	d2 h6	l1	l2	l3	Z	Kod no	EUR/parça		
mm	mm	mm	mm	mm					
3.000	4.000	50.000	10.000	13.400	6	3.000	17.00		
4.000	6.000	57.000	11.000	15.900	6	4.000	16.20	17.00	
5.000	6.000	57.000	13.000	17.900	6	5.000	15.40	16.20	
6.000	6.000	57.000	13.000	20.000	6	6.000	15.40	16.20	
8.000	8.000	63.000	19.000	26.000	6	8.000	18.40	19.20	
10.000	10.000	72.000	22.000	30.000	6	10.000	29.50	30.70	
12.000	12.000	83.000	26.000	36.000	6	12.000	40.00	41.20	
14.000	14.000	83.000	26.000	36.000	6	14.000	55.00	56.20	
16.000	16.000	92.000	32.000	42.000	6	16.000	72.00	74.00	
18.000	18.000	92.000	32.000	42.000	6	18.000	84.00	86.00	
20.000	20.000	104.000	38.000	52.000	6	20.000	103.00	105.00	

Çok ağızlı finiş freze (6-kesme ağızlı)

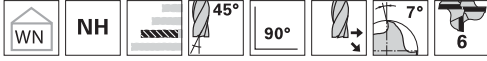

P	•
M	•
K	•
N	•
S	•
H	○

GUHRING NAVIGATOR
Kesme Şartları Sayfa 26

Merkez kesmesiz

Malzeme	Karbür	
Kaplama Tipi	F	F
Tip	NH	NH
Şaft Formu	HA	HB

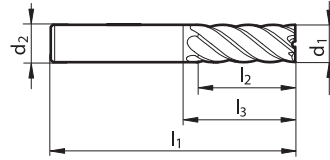

							Artikel no	19974	19975
							İndirim grubu	206	206
d1 e8	d2 h6	l1	l2	l3	Z	Kod no	EUR/parça		
mm	mm	mm	mm	mm					
4.000	6.000	63.000	16.000	20.900	6	4.000	24.00	24.80	
5.000	6.000	63.000	18.000	22.900	6	5.000	24.00	24.80	
6.000	6.000	63.000	18.000	26.000	6	6.000	22.00	22.80	
8.000	8.000	68.000	24.000	31.000	6	8.000	25.50	26.30	
10.000	10.000	80.000	30.000	38.000	6	10.000	45.00	46.20	
12.000	12.000	93.000	36.000	46.000	6	12.000	63.00	64.20	
14.000	14.000	100.000	42.000	53.000	6	14.000	88.00	89.20	
16.000	16.000	108.000	48.000	58.000	6	16.000	113.00	115.00	
18.000	18.000	114.000	54.000	64.000	6	18.000	142.00	144.00	
20.000	20.000	126.000	60.000	74.000	6	20.000	172.00	174.00	

Küresel Slot makap freze (2 kanallı)

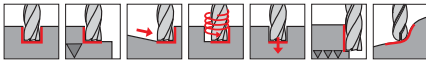
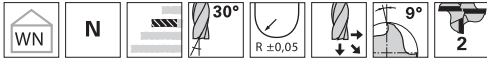

- P •
- M •
- K •
- N •
- S •
- H ○

GÜHRING NAVIGATOR
Kesme Şartları Sayfa 26

Merkez kesmeli

Malzeme	Karbür	
Kaplama Tipi	F	F
Tip	N	N
Şaft Formu	HA	HB

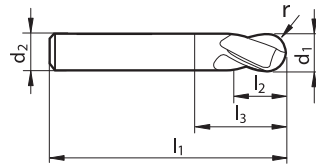

								Artikel no	19968	19969
								İndirim grubu	206	206
d1 e8	d2 h6	l1	l2	l3	r	Z	Kod no	EUR/parça		
mm	mm	mm	mm	mm	mm					
2.000	4.000	40.000	6.000	9.400	1.000	2	2.000	14.00		
3.000	4.000	50.000	7.000	11.900	1.500	2	3.000	14.00		
4.000	6.000	50.000	8.000	13.400	2.000	2	4.000	14.00	14.80	
5.000	6.000	50.000	10.000	16.900	2.500	2	5.000	14.00	14.80	
6.000	6.000	50.000	10.000	20.000	3.000	2	6.000	14.00	14.80	
8.000	8.000	60.000	19.000	27.000	4.000	2	8.000	16.50	17.30	
10.000	10.000	70.000	22.000	30.000	5.000	2	10.000	21.50	22.70	
12.000	12.000	75.000	26.000	39.000	6.000	2	12.000	32.50	33.70	
14.000	14.000	75.000	26.000	40.000	7.000	2	14.000	42.00	43.20	
16.000	16.000	75.000	26.000	43.000	8.000	2	16.000	51.00	53.00	
18.000	18.000	100.000	32.000	52.000	9.000	2	18.000	62.00	64.00	
20.000	20.000	100.000	32.000	50.000	10.000	2	20.000	83.00	85.00	

XL küresel slot matkap freze (2 kanallı)

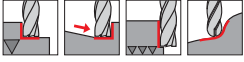
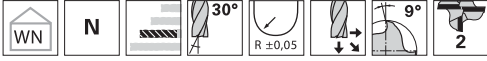

P	•
M	•
K	•
N	•
S	•
H	○

GUHRING NAVIGATOR
Kesme Şartları Sayfa 26

Merkez kesmeli

Malzeme	Karbür	
Kaplama Tipi	F	F
Tip	N	N
Şaft Formu	HA	HB

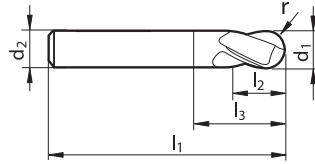

								Artikel no	19970	19971
								İndirim grubu	206	206
d1 e8	d2 h6	l1	l2	l3	r	Z	Kod no	EUR/parça		
mm	mm	mm	mm	mm	mm					
3.000	3.000	60.000	20.000	32.000	1.500	2	3.000	28.00		
4.000	4.000	60.000	20.000	32.000	2.000	2	4.000	29.50		
5.000	5.000	75.000	25.000	47.000	2.500	2	5.000	32.50		
6.000	6.000	75.000	30.000	39.000	3.000	2	6.000	36.50	37.30	
8.000	8.000	75.000	30.000	39.000	4.000	2	8.000	41.50	42.30	
10.000	10.000	100.000	40.000	60.000	5.000	2	10.000	56.00	57.20	
12.000	12.000	100.000	45.000	55.000	6.000	2	12.000	74.00	75.20	

Kaba ve finiş frezeleri

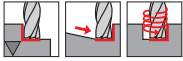

P	•
M	•
K	•
N	•
S	o
H	•

GUHRING NAVIGATOR
Kesme Şartları Sayfa 26

Merkez kesmeli

Malzeme	Karbür	
Kaplama Tipi	F	F
Tip	HRf	HRf
Şaft Formu	HA	HB

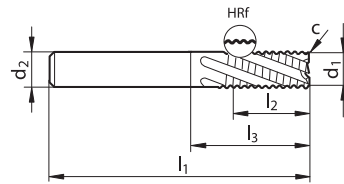

								Artikel no	19964	19965
								İndirim grubu	206	206
d1 h10	d2 h6	l1	l2	l3	c	Z	Kod no	EUR/parça		
mm	mm	mm	mm	mm	mm x 45°					
4.000	6.000	54.000	8.000	12.900	0.160	3	4.000	40.00	40.80	
5.000	6.000	54.000	8.000	14.400	0.200	3	5.000	40.00	40.80	
6.000	6.000	54.000	8.000	18.000	0.240	3	6.000	37.00	37.80	
8.000	8.000	58.000	11.000	22.000	0.320	3	8.000	43.00	43.80	
10.000	10.000	66.000	13.000	26.000	0.200	4	10.000	47.00	48.20	
12.000	12.000	73.000	16.000	28.000	0.240	4	12.000	55.00	56.20	
16.000	16.000	82.000	19.000	34.000	0.320	4	16.000	88.00	90.00	
20.000	20.000	92.000	19.000	42.000	0.400	4	20.000	131.00	133.00	

Kaba ve finiş frezeleri



P	•
M	•
K	•
N	•
S	○
H	•

GUHRING NAVIGATOR
Kesme Şartları Sayfa 24

Merkez kesmeli

Malzeme	Karbür	
Kaplama Tipi	HRf	HRf
Tip	HA	HB
Şaft Formu		

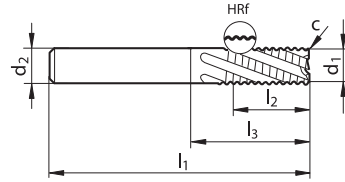

								Artikel no	19966	19967
								İndirim grubu	206	206
d1 h10	d2 h6	l1	l2	l3	c	Z	Kod no	EUR/parça		
mm	mm	mm	mm	mm	mm x 45°					
5.000	6.000	57.000	16.000	21.000	0.200	3	5.000	45.00	45.80	
6.000	6.000	57.000	16.000	21.000	0.240	3	6.000	41.50	42.30	
8.000	8.000	63.000	19.000	27.000	0.320	3	8.000	48.00	48.80	
10.000	10.000	72.000	22.000	32.000	0.200	4	10.000	52.00	53.20	
12.000	12.000	83.000	26.000	38.000	0.240	4	12.000	62.00	63.20	
16.000	16.000	92.000	32.000	44.000	0.320	4	16.000	98.00	100.00	
20.000	20.000	104.000	38.000	54.000	0.400	4	20.000	147.00	149.00	
25.000	25.000	121.000	45.000	65.000	0.600	5	25.000	190.00	192.50	



NAVIGATOR

GÜHRING NAVIGATOR Frezeler

Koyu hane ile yazılan rakamlar (İS no) ilk tercih.

a_e = Kesme genişliği

a_p = Kesme derinliği

Art. no. firma std. Company std. Company std.

* For large cutting depths on unstable machines f_z and v_c must be reduced or a 4-flute tool must be applied.

Rijit olmayan tezgahlarda derin kesme işlemlerinde f_z ve V_c faktörleri düşürülmeli ya da 4 ağızlı takım kullanılmalıdır

SONRAKİ SAYFLARDA AYNI DEĞİŞİKLİK UYGULANACAK

Kesici -Ø mm	İlerleme sütunu															
	37	38	39	40	41	42	43	44	45	46	47	48	49	50	51	52
	f_z (mm/teeth) mm / ağız															
2,00	0,001	0,001	0,001	0,002	0,002	0,004	0,005	0,006	0,007	0,008	0,010	0,012	0,014	0,016	0,018	0,020
3,00	0,002	0,002	0,003	0,003	0,004	0,007	0,010	0,010	0,010	0,015	0,016	0,013	0,019	0,022	0,024	0,030
5,00	0,005	0,006	0,007	0,009	0,010	0,014	0,020	0,020	0,022	0,025	0,026	0,026	0,028	0,030	0,032	0,038
6,00	0,006	0,008	0,009	0,011	0,013	0,017	0,024	0,025	0,027	0,031	0,029	0,033	0,039	0,036	0,041	0,047
8,00	0,010	0,012	0,014	0,016	0,019	0,024	0,032	0,032	0,035	0,042	0,042	0,047	0,053	0,052	0,058	0,064
10,00	0,013	0,015	0,018	0,021	0,025	0,030	0,038	0,039	0,044	0,050	0,053	0,059	0,065	0,066	0,073	0,080
12,00	0,010	0,018	0,022	0,026	0,030	0,036	0,046	0,048	0,052	0,059	0,063	0,072	0,079	0,085	0,090	0,100
16,00	0,020	0,023	0,027	0,032	0,038	0,045	0,054	0,058	0,063	0,071	0,079	0,088	0,095	0,100	0,110	0,120
20,00	0,023	0,028	0,033	0,038	0,045	0,057	0,066	0,073	0,080	0,090	0,097	0,100	0,110	0,120	0,130	0,140
25,00	0,030	0,035	0,040	0,045	0,055	0,065	0,075	0,100	0,120	0,130	0,140	0,150	0,165	0,170	0,180	0,190

Malzeme grupları	Malzeme Özellikleri Koyu haneli yazılar = malzeme DIN EN 10 027	Çekme mukavemeti MPa (N/mm ²)	Sertlik
Genel yapı çelikleri	1.0035 S185(St33), 1.0486 P275N(StE285), 1.0345 P235GH(H1), 1.0425 P265GH(H2) 1.0050 E295 (St50-2), 1.0070 E360 (St70-2), 1.8937 P500NH (WStE500)	≤500 ≤1000	
Otomat çelikleri	1.0718 11SMnPb30 (9SMnPb28), 1.0736 11SMn37 (9SMn36) 1.0727 46S20 (45S20), 1.0728 (60S20), 1.0757 46SPb20 (45SPb20)	≤850 ≤1000	
Alaşımız islah çelikleri	1.0402 C22, 1.1178 C30E (Ck30) 1.0503 C45, 1.1191 C45E (Ck45) 1.0601 C60, 1.1221 C60E (Ck60)	≤700 ≤850 ≤1000	
Alaşımli islah çelikleri	1.5131 50MnSi4, 1.7003 38Cr2, 1.7030 28Cr4 1.5710 36NiCr6, 1.7035 41Cr4, 1.7225 42CrMo4	≤1000 ≤1400	
Alaşımız sementasyon çelikleri	1.0301 (C10), 1.1121 C10E (Ck10)	≤850	
Alaşımli sementasyon çelikleri	1.7276 10CrMo11, 1.5125 11MnSi6 1.5752 15NiCr13, 1.7131 16MnCr5, 1.7264 20CrMo5	≤1000 ≤1400	
Nitrasyon çelikleri	1.8504 34CrAl6 1.8519 31CrMoV9, 1.8550 34CrAlNi7	≤1000 ≤1400	
Takım çelikleri	1.1750 C75W, 1.2067 102Cr6, 1.2307 29CrMoV9 1.2080 X210Cr12, 1.2083 X42Cr13, 1.2419 105WCr6, 1.2767 X45NiCrMo4	≤850 ≤1400	
Yüksek hız çelikleri	1.3243 S 6-5-2-5, 1.3343 S 6-5-2, 1.3344 S 6-5-3	≤1400	
Yay çelikleri	1.5026 55Si7, 1.7176 55Cr3, 1.8159 51CrV4 (51CrV4)		≤350 HB
Sertleştirilmiş çelikleri	-		≤48 HRC ≤66 HRC
Paslanmaz çelikler, kükürtlü ostenitli martenzitli	1.4005 X12CrS13, 1.4104 X14CrMoS17, 1.4105 X6CrMoS17, 1.4305 X8CrNiS18-9 1.4301 X5CrNi18-10 (V2A), 1.4541 X6CrNiTi18-10, 1.4571 X6CrNiMoTi 17-12-2 (V4A) 1.4057 X20CrNi172 (X17CrNi16-2), 1.4122 X39CrMo17-1, 1.4521 X2CrMoTi18-2	≤900 ≤1100 ≤1500	
Demir döküm	0.6010 EN-GJL-100 (GG10), 0.6020 EN-GJL-200 (GG20) 0.6025 EN-GJL-250 (GG25), 0.6035 EN-GJL-350 (GG35)		≤240 HB ≤350 HB
Sfero ve temper döküm	0.7050 EN-GJS-500-7 (GGG50), 0.8035 EN-GJMW-350-4 (GTW35) 0.7070 EN-GJS-700-2 (GGG70), 0.8170 EN-GJMB-700-2 (GTS70)		≤240 HB ≤350 HB
Sert döküm	-		≤350 HB
Yeni döküm malzemesi GGV	EN-GJV250 (GGV25), EN-GJV350 (GGV35) EN-GJV400 (GGV40), EN-GJV500 (GGV50), SiMo 6		≤220 HB ≤300 HB
Yeni döküm malzemesi ADI	EN-GJS-800-8 (ADI800), EN-GJS-1000-5 (ADI1000) EN-GJS-1200-2 (ADI1200), EN-GJS-1400-1 (ADI1400)	≤1000 ≤1400	
Özel alaşımli	Nimonic, Inconel, Monel, Hastelloy	≤2000	
Titanyum ve titanyum alaşımları	3.7024 Ti99,5, 3.7114 TiAl5Sn2,5, 3.7124 TiCu2 3.7154 TiAl6Zr5, 3.7165 TiAl6V4, 3.7184 TiAl4Mo4Sn2,5, -TiAl8Mo1V1	≤850 ≤1400	
Aluminyum ve Al alaşımları	3.0255 Al99,5, 3.2315 AlMgSi1, 3.3515 AlMg1	≤400	
Al-dövme alaşımları	3.0615 AlMgSiPb, 3.1325 AlCuMg1, 3.3245 AlMg3Si, 3.4365 AlZnMgCu1,5	≤650	
Al döküm alaşımları ≤ 10 % Si	3.2131 G-AlSi5Cu1, 3.2153 G-AlSi7Cu3, 3.2573 G-AlSi9	≤600	
Al döküm alaşımları ≤ 24 % Si	3.2581 G-AlSi12, 3.2583 G-AlSi12Cu, -G-AlSi12CuNiMg	≤600	
Magnezyum alaşımları	3.5200 MgMn2, 3.5812.05 G-MgAl8Zn1, 3.5612.05 G-MgAl6Zn1	≤400	
Bakır, düşük alaşımli	2.0070 SE-Cu, 2.1020 CuSn6, 2.1096 G-CuSn5ZnPb	≤500	
Pirinç, kısa talaşlı	2.0380 CuZn39Pb2, 2.0401 CuZn39Pb3, 2.0410 CuZn43Pb2	≤600	
uzun talaşlı	2.0250 CuZn20, 2.0280 CuZn33, 2.0332 CuZn37Pb0,5	≤600	
Bronz kısa talaş	2.1090 CuSn7ZnPb, 2.1170 CuPb5Sn5, 2.1176 CuPb10Sn	≤600	
	2.0790 CuNi18Zn19Pb	≤850	
Bronz, uzun talaş	2.0916 CuAl5, 2.0960 CuAl9Mn, 2.1050 CuSn10	≤850	
	2.0980 CuAl1Ni, 2.1247 CuBe2	≤1000	
Plastikler, aramit elyaf takviyeli cam-/ Karbon elyaf takviyeli	Epoxy resin, Resopal, Pertinax, Moltopren Plexiglass, Hostalen, Novodur, Makralon	≤150 ≤100	
	Kevlar	≤1000	
	GFK/CFK	≤1000	

Corrections V_c and f_z

Slot frezeleme

Kaba

	Karbür N	Karbür N	Karbür N	Karbür N	Karbür NH	Karbür W	Karbür N	Karbür HRf
HA	19988	19982	19990	19984	19986	19994/19996	19980	19964/19966
HB	19989	19983	19991	19985	19987	19995/19997 19992/19993	19981	19965/19967

HPC

54HRC

54HRC



a_e = 1 x D



a_e = 1 x D



a_e = 1 x D



a_e = 1 x D



a_e = 1 x D



a_e = 1 x D



a_e = 0,5-1,0 x D



a_e = 0,5-1,0 x D

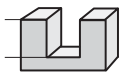

a_p = 0,5 x D

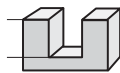

a_p = 0,5 x D

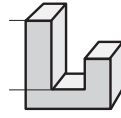

a_p = 2 x D

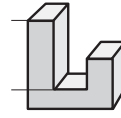

a_p = 2 x D

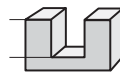

a_p = 1 x D

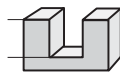

a_p = 1 x D



a_p = 1 x D



a_p = 1 x D

v _c m/min	Feed col. no.	v _c m/min	Feed col. no.	v _c m/min	Feed col. no.	v _c m/min	Feed col. no.	v _c m/min	Feed col. no.	v _c m/min	Feed col. no.	v _c m/min	Feed col. no.	v _c m/min	Feed col. no.
85 - 105	42	85 - 105	42	72 - 88	39	72 - 88	39	94 - 116	43			170 - 208	51		
81 - 99	41	81 - 99	41	67 - 83	38	67 - 83	38	89 - 109	42			157 - 193	50		
85 - 105	41	85 - 105	41	72 - 88	38	72 - 88	38	94 - 116	42			170 - 208	50		
63 - 77	42	63 - 77	42	54 - 66	39	54 - 66	39	69 - 85	43			126 - 154	49		
85 - 105	41	85 - 105	41	72 - 88	38	72 - 88	38	94 - 116	42			170 - 208	50		
76 - 94	41	76 - 94	41	63 - 77	38	63 - 77	38	84 - 104	42			151 - 185	50		
63 - 77	42	63 - 77	42	54 - 66	39	54 - 66	39	69 - 85	43			126 - 154	49		
76 - 94	42	76 - 94	42	63 - 77	39	63 - 77	39	84 - 104	43			151 - 185	49		
63 - 77	42	63 - 77	42	54 - 66	39	54 - 66	39	69 - 85	43			126 - 154	48	72 - 88	39
90 - 110	41	90 - 110	41	67 - 83	38	67 - 83	38	99 - 121	42			189 - 231	50		
76 - 94	41	76 - 94	41	63 - 77	38	63 - 77	38	84 - 104	42			151 - 185	50	86 - 106	41
54 - 66	42	54 - 66	42	45 - 55	39	45 - 55	39	59 - 73	43			113 - 139	49	64 - 80	40
85 - 105	41	85 - 105	41	72 - 88	38	72 - 88	38	94 - 116	42			170 - 208	50	97 - 119	41
76 - 94	40	76 - 94	40	63 - 77	37	63 - 77	37	84 - 104	41			151 - 185	48	86 - 106	39
76 - 94	41	76 - 94	41	63 - 77	38	63 - 77	38	84 - 104	42			151 - 185	50	86 - 106	41
63 - 77	40	63 - 77	40	54 - 66	37	54 - 66	37	69 - 85	41			126 - 154	48	72 - 88	39
45 - 55	42	45 - 55	42	40 - 50	39	40 - 50	39	49 - 61	43			94 - 116	49	54 - 66	47
45 - 55	40							49 - 61	41			94 - 116	48	54 - 66	26
45 - 55	40							49 - 61	41			44 - 54	46	25 - 31	38
														18 - 22	38
45 - 55	42	45 - 55	42					49 - 61	43			80 - 100	49		
40 - 50	40	40 - 50	40					45 - 55	41			70 - 90	48		
36 - 44	41	36 - 44	41					39 - 49	42			65 - 70	49	43 - 53	40
108 - 132	41	108 - 132	41	94 - 116	38	94 - 116	38	118 - 146	42			220 - 270	50	126 - 154	42
99 - 121	40	99 - 121	40	85 - 105	37	85 - 105	37	108 - 134	41			201 - 247	49	115 - 141	41
90 - 110	41	90 - 110	41	81 - 99	38	81 - 99	38	99 - 121	42			182 - 224	50	104 - 128	42
81 - 99	40	81 - 99	40	67 - 83	37	67 - 83	37	89 - 109	41			157 - 193	49	90 - 110	41
54 - 66	40	54 - 66	40					59 - 73	41			107 - 131	47	61 - 75	39
27 - 33	40	27 - 33	40					29 - 37	41			56 - 70	48		
45 - 55	40	45 - 55	40	58 - 72	37	58 - 72	37	49 - 61	41			54 - 86	43		
36 - 44	40	36 - 44	40	31 - 39	37	31 - 39	37	39 - 49	41			44 - 72	42		
405 - 495	43									297 - 363	46				
495 - 605	43									360 - 440	46				
198 - 242	42							217 - 267	43	144 - 176	45				
162 - 198	43							178 - 218	44	117 - 143	46				
225 - 275	44									171 - 209	47				
108 - 132	43							118 - 146	44	81 - 99	46				
90 - 110	43							99 - 121	44	72 - 88	46			117 - 143	42
81 - 99	42									67 - 83	45				
90 - 110	42							99 - 121	43	72 - 88	45			117 - 143	42
72 - 88	41							79 - 97	42	63 - 77	44			87 - 107	41
72 - 88	42									63 - 77	45				
63 - 77	40									54 - 66	43				
108 - 132	40									81 - 99	43				
99 - 121	40									72 - 88	43				

1 x D = 75%
1,5 x D = 50%

1 x D = 75%
1,5 x D = 50%

3 x D = 50%

3 x D = 50%

1,5 x D = 50%

1,5 x D = 50%

a_e = 1,5 x D = 50%
a_p = 0,25 x D = 150%

a_e = 0,5 x D = 120%

GÜHRINGNAVIGATOR Frezeler

Koyu hane ile yazılan rakamlar (İS no) ilk tercih.

a_e = Kesme genişliği

a_p = Kesme derinliği



* For large cutting depths on unstable machines f_z and v_c must be reduced or a 4-flute tool must be applied.

Kesici -Ø mm	İlerleme sütunu															
	37	38	39	40	41	42	43	44	45	46	47	48	49	50	51	52
	f_z (mm/tooth)															
2,00	0,001	0,001	0,001	0,002	0,002	0,004	0,005	0,006	0,007	0,008	0,010	0,012	0,014	0,016	0,018	0,020
3,00	0,002	0,002	0,003	0,003	0,004	0,007	0,010	0,010	0,010	0,015	0,016	0,013	0,019	0,022	0,024	0,030
5,00	0,005	0,006	0,007	0,009	0,010	0,014	0,020	0,020	0,022	0,025	0,026	0,026	0,028	0,030	0,032	0,038
6,00	0,006	0,008	0,009	0,011	0,013	0,017	0,024	0,025	0,027	0,031	0,029	0,033	0,039	0,036	0,041	0,047
8,00	0,010	0,012	0,014	0,016	0,019	0,024	0,032	0,032	0,035	0,042	0,042	0,047	0,053	0,052	0,058	0,064
10,00	0,013	0,015	0,018	0,021	0,025	0,030	0,038	0,039	0,044	0,050	0,053	0,059	0,065	0,066	0,073	0,080
12,00	0,010	0,018	0,022	0,026	0,030	0,036	0,046	0,048	0,052	0,059	0,063	0,072	0,079	0,085	0,090	0,100
16,00	0,020	0,023	0,027	0,032	0,038	0,045	0,054	0,058	0,063	0,071	0,079	0,088	0,095	0,100	0,110	0,120
20,00	0,023	0,028	0,033	0,038	0,045	0,057	0,066	0,073	0,080	0,090	0,097	0,100	0,110	0,120	0,130	0,140
25,00	0,030	0,035	0,040	0,045	0,055	0,065	0,075	0,100	0,120	0,130	0,140	0,150	0,165	0,170	0,180	0,190

Malzeme grupları	Malzeme Özellikleri Koyu haneli yazılar = malzeme DIN EN 10 027	Çekme mukavemeti MPa (N/mm ²)	Sertlik
Genel yapı çelikleri	1.0035 S185(St33), 1.0486 P275N(StE285), 1.0345 P235GH(H1), 1.0425 P265GH(H2) 1.0050 E295 (St50-2), 1.0070 E360 (St70-2), 1.8937 P500NH (WStE500)	≤500 ≤1000	
Otomat çelikleri	1.0718 11SMnPb30 (9SMnPb28), 1.0736 11SMn37 (9SMn36) 1.0727 46S20 (45S20), 1.0728 (60S20), 1.0757 46SPb20 (45SPb20)	≤850 ≤1000	
Alaşımız islah çelikleri	1.0402 C22, 1.1178 C30E (Ck30) 1.0503 C45, 1.1191 C45E (Ck45) 1.0601 C60, 1.1221 C60E (Ck60)	≤700 ≤850 ≤1000	
Alaşımli islah çelikleri	1.5131 50MnSi4, 1.7003 38Cr2, 1.7030 28Cr4 1.5710 36NiCr6, 1.7035 41Cr4, 1.7225 42CrMo4	≤1000 ≤1400	
Alaşımız sementasyon çelikleri	1.0301 (C10), 1.1121 C10E (Ck10)	≤850	
Alaşımli sementasyon çelikleri	1.7276 10CrMo11, 1.5125 11MnSi6 1.5752 15NiCr13, 1.7131 16MnCr5, 1.7264 20CrMo5	≤1000 ≤1400	
Nitrasyon çelikleri	1.8504 34CrAl6 1.8519 31CrMoV9, 1.8550 34CrAlNi7	≤1000 ≤1400	
Takım çelikleri	1.1750 C75W, 1.2067 102Cr6, 1.2307 29CrMoV9 1.2080 X210Cr12, 1.2083 X42Cr13, 1.2419 105WCr6, 1.2767 X45NiCrMo4	≤850 ≤1400	
Yüksek hız çelikleri	1.3243 S 6-5-2-5, 1.3343 S 6-5-2, 1.3344 S 6-5-3	≤1400	
Yay çelikleri	1.5026 55Si7, 1.7176 55Cr3, 1.8159 51CrV4 (51CrV4)		≤350 HB
Sertleştirilmiş çelikleri	-		≤48 HRC ≤66 HRC
Paslanmaz çelikler, kükürtlü ostenitli martenzitli	1.4005 X12CrS13, 1.4104 X14CrMoS17, 1.4105 X6CrMoS17, 1.4305 X8CrNiS18-9 1.4301 X5CrNi18-10 (V2A), 1.4541 X6CrNiTi18-10, 1.4571 X6CrNiMoTi 17-12-2 (V4A) 1.4057 X20CrNi172 (X17CrNi16-2), 1.4122 X39CrMo17-1, 1.4521 X2CrMoTi18-2	≤900 ≤1100 ≤1500	
Demir döküm	0.6010 EN-GJL-100 (GG10), 0.6020 EN-GJL-200 (GG20) 0.6025 EN-GJL-250 (GG25), 0.6035 EN-GJL-350 (GG35)		≤240 HB ≤350 HB
Sfero ve temper döküm	0.7050 EN-GJS-500-7 (GGG50), 0.8035 EN-GJMW-350-4 (GTW35) 0.7070 EN-GJS-700-2 (GGG70), 0.8170 EN-GJMB-700-2 (GTS70)		≤240 HB ≤350 HB
Sert döküm	-		≤350 HB
Yeni döküm malzemesi GGV	EN-GJV250 (GGV25), EN-GJV350 (GGV35) EN-GJV400 (GGV40), EN-GJV500 (GGV50), SiMo 6		≤220 HB ≤300 HB
Yeni döküm malzemesi ADI	EN-GJS-800-8 (ADI800), EN-GJS-1000-5 (ADI1000) EN-GJS-1200-2 (ADI1200), EN-GJS-1400-1 (ADI1400)	≤1000 ≤1400	
Özel alaşımlı	Nimonic, Inconel, Monel, Hastelloy	≤2000	
Titanyum ve titanyum alaşımları	3.7024 Ti99,5, 3.7114 TiAl5Sn2,5, 3.7124 TiCu2 3.7154 TiAl6Zr5, 3.7165 TiAl6V4, 3.7184 TiAl4Mo4Sn2,5, -TiAl8Mo1V1	≤850 ≤1400	
Aluminyum ve Al alaşımları	3.0255 Al99,5, 3.2315 AlMgSi1, 3.3515 AlMg1	≤400	
Al-dövme alaşımları	3.0615 AlMgSiPb, 3.1325 AlCuMg1, 3.3245 AlMg3Si, 3.4365 AlZnMgCu1,5	≤650	
Al döküm alaşımları	3.2131 G-ALSi5Cu1, 3.2153 G-ALSi7Cu3, 3.2573 G-ALSi9 3.2581 G-ALSi12, 3.2583 G-ALSi12Cu,- G-ALSi12CuNiMg	≤600 ≤600	
Magnezyum alaşımları	3.5200 MgMn2, 3.5812.05 G-MgAl8Zn1, 3.5612.05 G-MgAl6Zn1	≤400	
Bakır, düşük alaşımlı	2.0070 SE-Cu, 2.1020 CuSn6, 2.1096 G-CuSn5ZnPb	≤500	
Pirinç, kısa talaşlı uzun talaşlı	2.0380 CuZn39Pb2, 2.0401 CuZn39Pb3, 2.0410 CuZn43Pb2 2.0250 CuZn20, 2.0280 CuZn33, 2.0332 CuZn37Pb0,5	≤600 ≤600	
Bronz kısa talaş	2.1090 CuSn7ZnPb, 2.1170 CuPb5Sn5, 2.1176 CuPb10Sn 2.0790 CuNi18Zn19Pb	≤600 ≤850	
Bronz, uzun talaş	2.0916 CuAl5, 2.0960 CuAl9Mn, 2.1050 CuSn10 2.0980 CuAl1Ni, 2.1247 CuBe2	≤850 ≤1000	
Plastikler, aramit elyaf takviyeli cam-/ Karbon elyaf takviyeli	Epoxy resin, Resopal, Pertinax, Moltopren Plexiglass, Hostalen, Novodur, Makralon Kevlar GFK/CFK	≤150 ≤100 ≤1000 ≤1000	

Corrections v_c and f_z

	Finiş		Finiş		Kopyalama	
	Karbür	Karbür	Karbür	Karbür	Karbür	Karbür
HA	N	N	NH	NH	N	N
HB	19978	19976	19972	19974*	19968	19970
	19979	19977	19973	19975*	19969	19971

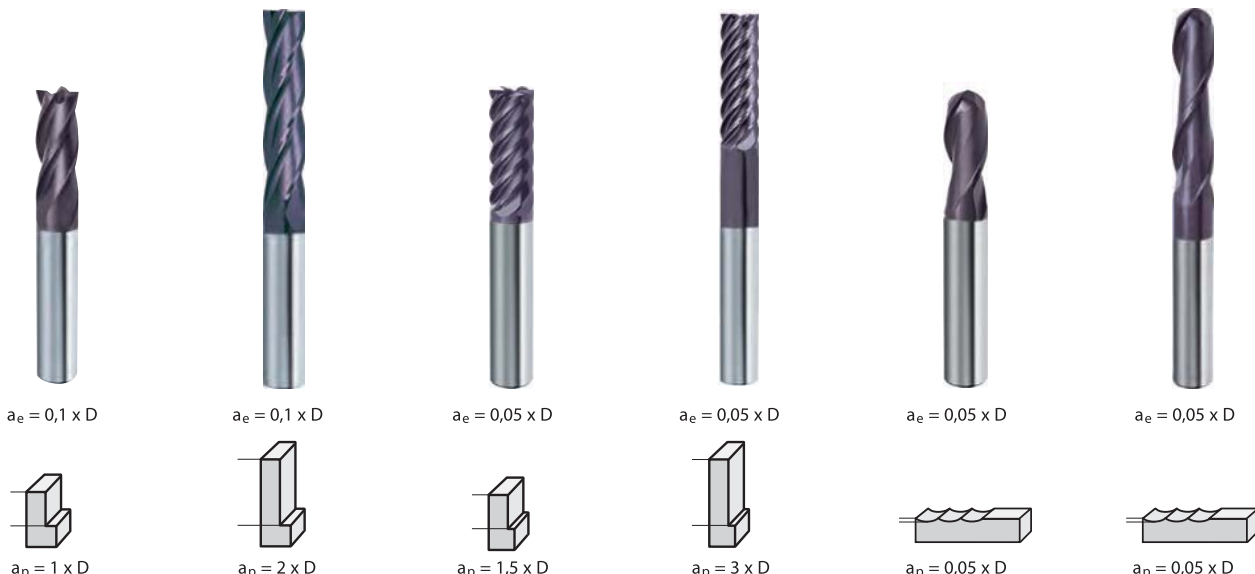

v_c m/min	Feed col. no.	v_c m/min	Feed col. no.	v_c m/min	Feed col. no.	v_c m/min	Feed col. no.	v_c m/min	Feed col. no.	v_c m/min	Feed col. no.
157 - 193	48	103 - 127	43	171 - 209	48	136 - 168	45	153 - 187	48	153 - 187	46
144 - 176	47	94 - 116	42	157 - 193	47	126 - 154	44	144 - 176	47	144 - 176	45
157 - 193	47	103 - 127	42	171 - 209	47	136 - 168	44	153 - 187	47	153 - 187	45
117 - 143	46	81 - 99	41	126 - 154	46	100 - 124	43	153 - 187	46	153 - 187	44
157 - 193	47	103 - 127	42	171 - 209	47	136 - 168	44	135 - 165	47	135 - 165	45
144 - 176	47	90 - 110	42	153 - 187	47	122 - 150	44	135 - 165	47	135 - 165	45
117 - 143	46	76 - 94	41	126 - 154	46	100 - 124	43	117 - 143	46	117 - 143	44
139 - 171	46	90 - 110	41	153 - 187	46	122 - 150	43	126 - 154	46	126 - 154	44
117 - 143	45	76 - 94	40	126 - 154	45	100 - 124	42	153 - 187	45	153 - 187	43
175 - 215	47	99 - 121	42	189 - 231	47	151 - 185	44	198 - 242	47	198 - 242	45
139 - 171	47	90 - 110	42	153 - 187	47	122 - 150	44	171 - 209	47	171 - 209	45
103 - 127	46	67 - 83	41	117 - 143	46	93 - 115	43	108 - 132	46	108 - 132	44
157 - 193	47	103 - 127	42	171 - 209	47	136 - 168	44	144 - 176	47	144 - 176	45
144 - 176	45	90 - 110	40	153 - 187	45	122 - 150	42	135 - 165	45	135 - 165	43
139 - 171	47	90 - 110	42	153 - 187	47	122 - 150	44	135 - 165	47	135 - 165	45
117 - 143	45	76 - 94	40	126 - 154	45	100 - 124	42	117 - 143	45	117 - 143	43
90 - 110	46	58 - 72	41	94 - 116	46	75 - 93	43	85 - 105	46	85 - 105	44
				94 - 116	45	75 - 93	42	85 - 105	45	85 - 105	43
				49 - 61	43	39 - 49	41	49 - 61	44	49 - 61	42
90 - 110	46			94 - 116	46	75 - 93	43	85 - 105	46	85 - 105	44
76 - 94	45			81 - 99	45	64 - 80	42	76 - 94	45	76 - 94	43
72 - 88	46			76 - 94	46	61 - 75	43	67 - 83	46	67 - 83	44
189 - 231	47	135 - 165	42	220 - 270	47	132 - 162	44	198 - 242	47	198 - 242	45
189 - 231	46	121 - 149	41	202 - 248	46	121 - 149	43	189 - 231	46	189 - 231	44
171 - 209	47	112 - 138	42	180 - 220	47	108 - 132	44	171 - 209	47	171 - 209	45
144 - 176	46	94 - 116	41	157 - 193	46	94 - 116	41	144 - 176	46	144 - 176	44
99 - 121	44							99 - 121	44	99 - 121	42
54 - 66	45			54 - 66	45	32 - 40	42	49 - 61	45	49 - 61	43
90 - 110	45	58 - 72	40	94 - 116	45	56 - 70	42				
72 - 88	44	45 - 55	39	76 - 94	44	45 - 57	41				
765 - 935	50	450 - 550	45	810 - 990	50	486 - 594	41	720 - 880	50	720 - 880	48
				720 - 880	50	432 - 528	41	855 - 1045	50	855 - 1045	48
373 - 457	48	225 - 275	43	405 - 495	48	243 - 297	45	342 - 418	48	342 - 418	46
306 - 374	49	180 - 220	44	324 - 396	49	194 - 238	46	288 - 352	49	288 - 352	47
				450 - 550	50			405 - 495	50	405 - 495	48
198 - 242	49	135 - 165	44	216 - 264	49			180 - 220	49	180 - 220	47
180 - 220	48	108 - 132	43	198 - 242	48	118 - 146	45	171 - 209	48	171 - 209	46
144 - 176	48	90 - 110	43	162 - 198	48			162 - 198	48	162 - 198	46
180 - 220	48	108 - 132	43	198 - 242	48	118 - 146	45	180 - 220	48	180 - 220	46
135 - 165	47			153 - 187	47	91 - 113	44	171 - 209	47	171 - 209	45
				153 - 187	47			198 - 242	47	198 - 242	45
				126 - 154	46	75 - 93	43	189 - 231	46	189 - 231	44
				216 - 264	46						
				198 - 242	46						

$a_p 2 \times D = 50\%$ $a_p 3 \times D = 50\%$ $a_p 0,1 \times D = 75\%$

Guhring takım dolabı sistemleri TM 326, TM426 and TM526 takım depolama ve takım yönetimini iyi duruma getirir.
Takım stoğunda maksimum güvenlik ve takım yönetim şeffaflığı!



GUHRING



TM

Tool Management
Powered by

GÜHRING

GM 300 | GÜHRO JET |

ALINDAN SU VERMELİ TAKIM TUTUCULAR



Takım tutucularımız için ayrıntılı bilgileri GM300 kataloğunda bulabilirsiniz.

P	Çelik, yüksek alaşımı çelikler
M	Paslanmaz çelik
K	Dökme demir, sfero ve temper Döküm
N	Alüminyum ve diğer demir dışı metaller
S	Özel, süper ve titanyum alaşımları
H	Sertleştirilmiş çelik ve soğutulmuş dökme demir

Aşağıdaki fiyat ve programın sayfalarında uygulama grupları ve maksimum çekme dayanımı ve sertlik ayrıntılar için uygunluğu hakkında her aracı önerileri bulacaksınız:







- En uygun
- Kullanabilirlik
- Sınırlı uygunluk

Coatings

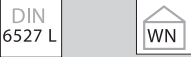
KAPLAMALAR

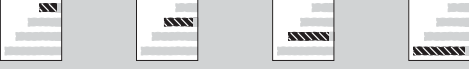
○ bright	● A TiAlN	● P AlCrN	● S Sirius	● Y Signum
○ steam tempered	● C TiCN	● S TiN	● F FIRE/nano FIRE	
● nitrided	● Cb Carbo	● M MolyGlide	● a TiAlN nanoA	

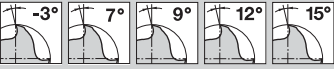
Pictograms

Malzeme	VHM
	Solid carbide finest grain (HM-UF)
Sap form	 to DIN 6535
Standart	 to DIN to Guhring standard
Tip	N W NH HRf
Uygulama	 Slotting Roughing Ramping Helix Drilling Finishing Copying
Uzunluk	 short (DIN) long (DIN) medium extra length
Kesme ağız sayısı	 no. of major cutting edges
Helis açısı	 Size of helix angle / no. of different helix angles
Boşluk açısı	 Rake angle of circumference cutting edges
Kesici ağız formu	 Corner chamfer Radius with tolerance
İlerleme	 for lateral feed for lateral feed and oblique plunging for lateral feed, oblique plunging and drilling

Delik Delme



Kesme Klavuzları, ovalama ve diş frezleme



Frezleme



PCD



Raybalama



Havşalama ve şapak alma



Özel Takım Çözümleri



Modüler takım tutucu sistemleri



Takım bileme servisi



Merkez

Çerkeşli Osb. Mah. İmes Osb.
3.Cad. No:7 Dilovası / KOCAELİ
Tel :0262 290 84 57 Fax: 0262 290 87 09

İstanbul Ofis

Balıkesir Cad. No:6 Uprise Elit Residence
D:285 Soğanlık Yenimahalle - Kartal / İstanbul
Tel: 0216 504 42 75 Fax: 0216 504 42 76

İzmir Şube

Atatürk Org. San. Bölgesi
10027 Sk. No:2 Çiğli / İZMİR
Tel: 0232 328 00 58 Fax: 0232 328 01 33